

FLOW

Averaging Pitot Tube - Flobar

Tubes de Pitot

The Flo-Bar is an Averaging Pitot Tube flow sensor for use on pipes, ducts or chimneys. Differential pressure created across the Flo-Bar has the standard square root relationship to flow rate, making a simple, removable sensor for installation or retrofit on flowlines of any size.

The unique design of the Flo-Bar profile provides a high accuracy, wide rangeability sensor: the standard integral manifold allows simple process isolation and easy installation of a DP measurement cell.

- Flow sensor for liquids, gases or steam
- $\pm 1\%$ Accuracy with standard square root flow output
- Full electron beam welded construction
- Unique profile sensor with flow averaging
- Integral 3 valve manifold
- Simple direct mounting of DP transmitter if required

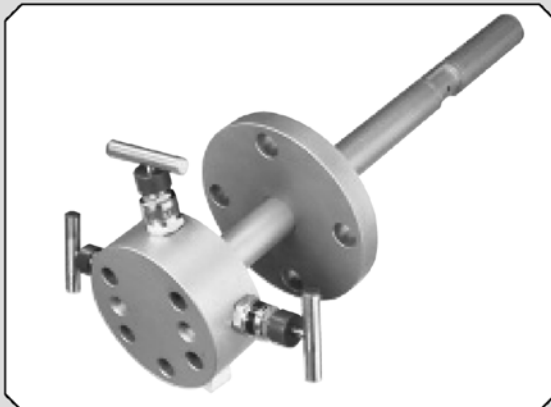

OPERATING PRINCIPLE

The Flo-Bar brings modern production techniques and design to the classic Pitot Tube flow measurement technique. The Flo-Bar is mounted across the pipe diameter, with a number of impact pressure sensing ports on the upstream face. Liquid and gas flows produce an impact pressure, in accordance with well-established formulae. The Flo-Bar averages this pressure across the pipe diameter, to take account of any flow profile irregularities. Downstream there is a single pressure sensing port; the precision engineered profile of the Flo-Bar at this reference pressure position ensures a stable separation for flow vortices, giving a stable flow calibration factor over a wide flow turndown.

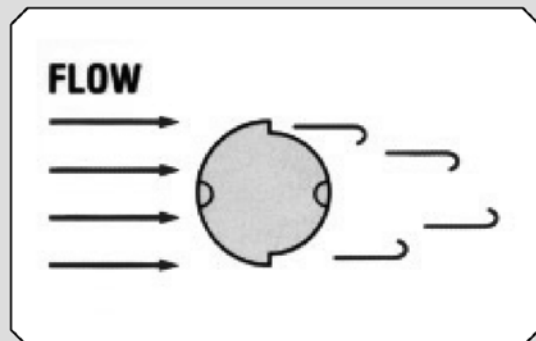

The differential pressure developed across the Flo-Bar is proportional to the square of the flow velocity, and can be measured using either a DP cell, a simple mechanical pressure gauge, or even displayed on a liquid U-tube manometer – depending on the application requirement. The Flo-Bar is available with a number of standard options. Particularly useful is the integral three valve manifold.

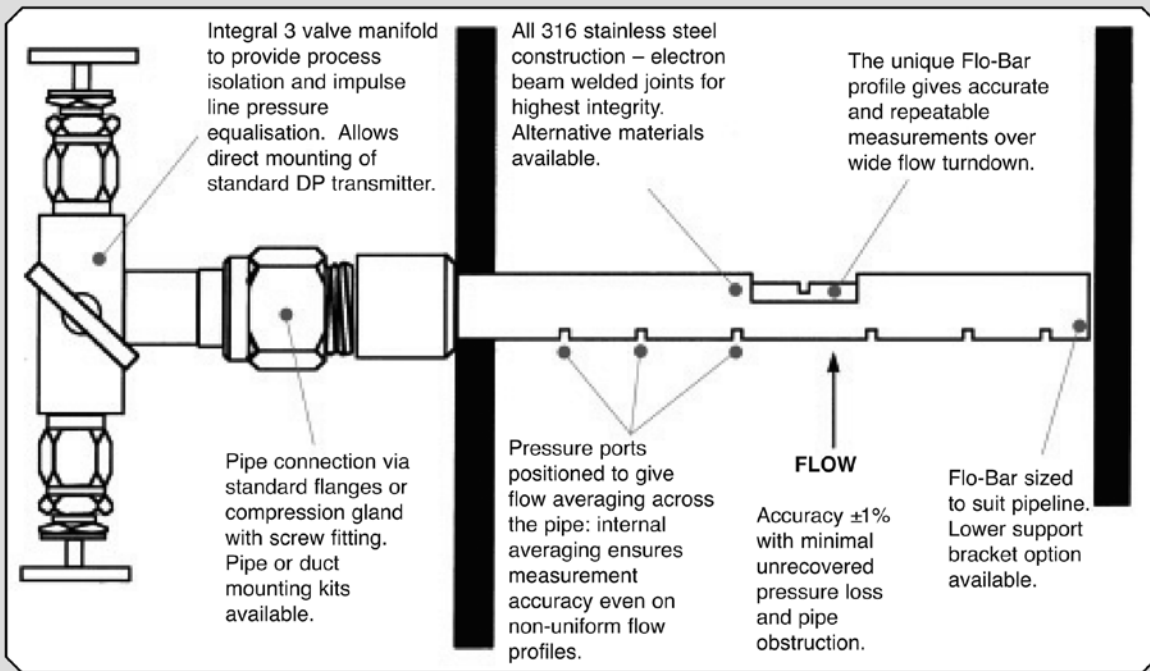

CUSTOMS CALIBRATION

The relationship between fluid flow and differential pressure for the Flo-Bar has been calculated using the well-established Bernoulli theory, and confirmed by independent flow test laboratory calibrations.

For each specific application, data on the flowing fluid and process conditions are used to produce a flow calibration curve. Within the software, separate calculations check for resonance effects and strength limitations in high velocity flows and recommend the use of a larger diameter Flo-Bar or an end support when this is necessary. Each quotation is accompanied by its own calculation sheet and calibration graph, to provide reassurance that the correct site data has been used, and to show the relevant DP values.

The Flo-Bar calculation sheet can be used to select a suitable DP measurement system for the application. Available from Roxspur are electronic transmitters and alarms, standard DP cells and mechanical gauges.

The calibration graph shown illustrates the differential pressure generated by water flow velocity for a 25mm diameter Flo-Bar in a 250mm pipe.

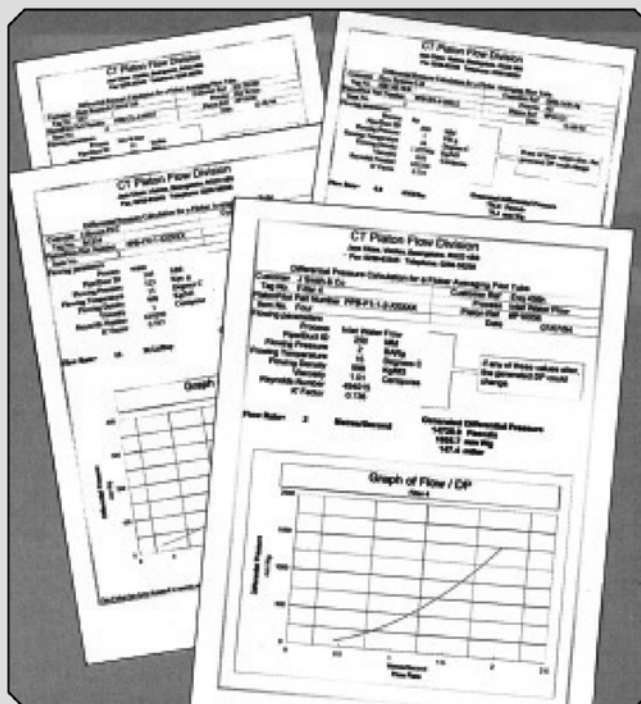

Site data required to produce a Flo-Bar calculation sheet includes fluid type, temperature and pressure, normal flow rate or required flow range, pipework internal dimensions and pipe wall thickness.

FLOW RANGE AND MODELS

Flo-Bar Averaging Pitot Tubes are available in three versions, suitable for different pipe size ranges and flow conditions. Model PPA uses a 13mm diameter tube and is suitable for small sized pipes, ducts and ventilation systems. The standard PPB Flo-Bar is 25mm diameter, covering the mid range of pipe sizes. Larger ducts such as chimneys or trunk liquid mains would use the 60mm diameter PPC unit. The graph shows the maximum water flow rates measurable for the three Flo-Bar models, for increasing pipe size.

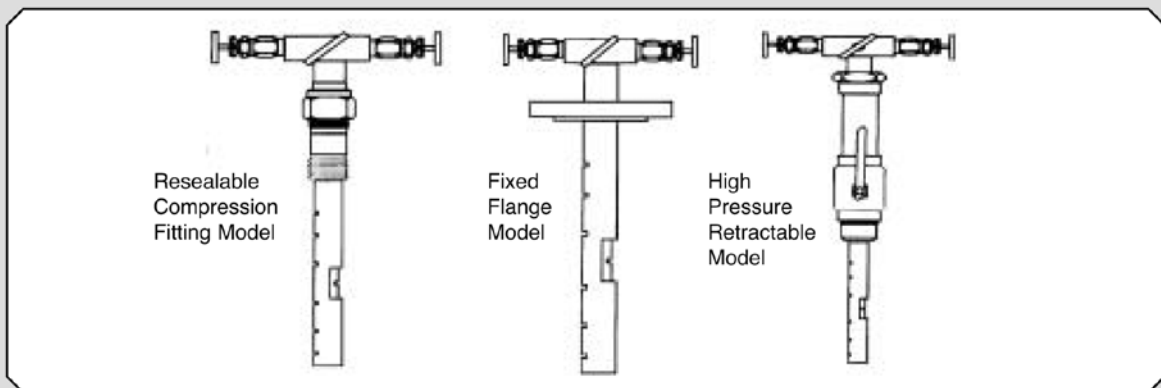
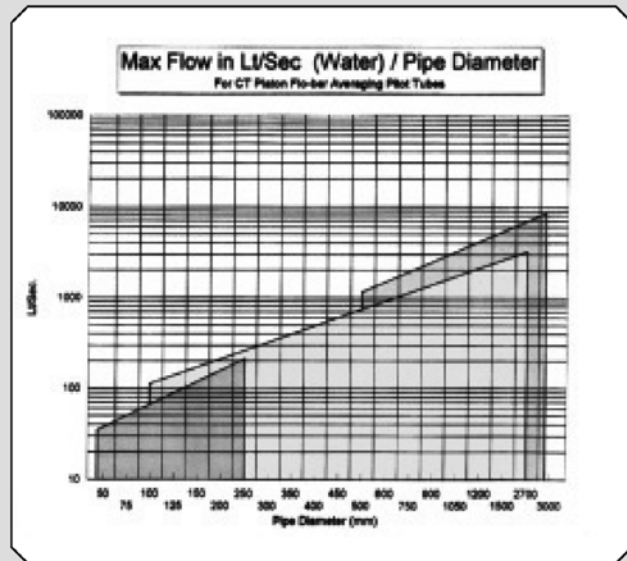

MODELS AVAILABLE

Flo-Bar models are available with different types of pipe installation fittings. The simplest approach is to use a compression fitting screwed into the pipeline. Alternatively, the Flo-Bar can be supplied flanged. Roxspur can supply the weld boss or flanged standoff. Where the installation requires the Flo-Bar to be retracted under line pressure, for pipe cleaning etc, valved retraction headwork options are available, subject to line pressure limitations. For pipe sizes 2" and below, in line Pitot pipe sections are available. For more complex pipe or duct configurations, multiple Pitot arrays with flow straighteners are available.

All the above models have the standard options of integral three valve manifolds or alternative impulse line connections.

For further information and model codes, please consult leaflet DS1711.

READOUT OPTIONS

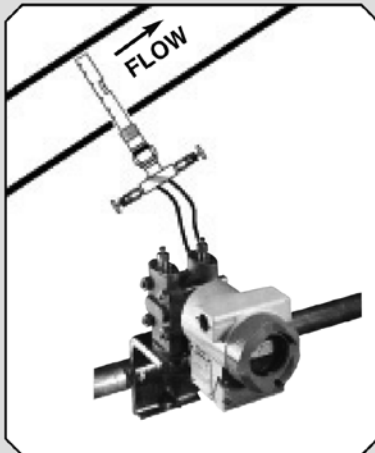

Differential Pressure Transmitter

The most frequently used measurement system with a Flo-Bar flow sensor is a conventional DP transmitter, either mounted directly on the Flo-Bar manifold, or separately mounted and connected to the Flo-Bar via impulse tubes.

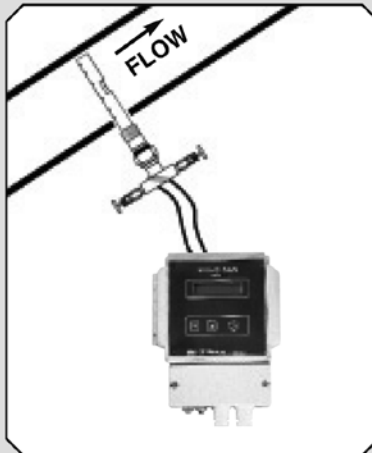

Micro-Bar Electronics

For dry gas flow measurement the Micro-Bar low range differential pressure transmitter and alarm, is specifically designed for flow display on Flo-Bar installations. This provides 4-20mA and totaliser pulse outputs. Ask for Data Sheet DS 1720.

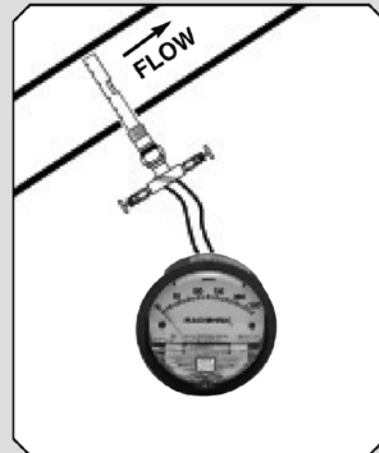

Flow DP Gauge

Differential pressure indicators can be installed to monitor the Flo-Bar generated DP, giving a simple visual indication of flow rate.

Tubes de Pitot

INSTALLATION INFORMATION

The installation of a Flo-Bar is straightforward, but must follow the normal rules stated for Orifice Plate or similar DP devices in BS 1042/ISO 5167. In general this means siting the Averaging Pitot Tube at least 7 diameters downstream of a single bend, and 3 diameters upstream of a similar obstruction.

On horizontal pipes, the positioning of the Pitot Tube must not allow condensation in gas flow times, or air bubbles in liquid flows, to collect in the head. So for gas flow measurement, for example, the Flo-Bar head must be above the pipeline, to allow any liquids to drain away.

Flo Bar units can be installed in horizontal, vertical or angled pipelines: the position across the pipe diameter and the alignment of the pressure ports must be maintained within 3σ for the quoted accuracy to be achieved.

More information is provided in the Flo-Bar data sheet and manual, available on request.

Every effort has been made during the preparation of this document to ensure the accuracy of statements and specifications. However, we do not accept liability for damage, injury, loss or expense caused by errors or omissions made. We reserve the right to withdraw or amend products or documentation without notice.



0043



CERTIFICATE NO. 22358

